

**PARTS LIST**

MARK	PART NO.	QUAN.	DESCRIPTION	UNIT WGT.	TOTAL WGT.					
1	69040-M	1	V-210 Desander Manifold		853.65	10	B03F52081300028	4	Cap Screw, H,H,1/2-13 x 1 3/4	0.18
2	DL1000	2	Double Life 10" Cone Assembly		196.00	11	W01052220908000	8	Flatwasher 1/2 Nom.	0.18
3	DL10LRE	2	Double Life Discharge Elbow, 5"		57.30	12	B03F52081300028	4	Lockwasher Std. Spiral, 1/2	0.10
4	68014	6	Coupling, Victaulic Style 75, 5"		33.00	13	N16052081300000	4	Hex Nut 1/2-13	0.10
5	68017	3	Coupling, Victaulic Style 75, 8"		37.50	14	B03F52061600020	4	Cap Screw H,H, 3/8-16 x 1 1/4	0.15
6	68053	2	Pipe Nipple, 8" Std. (Grv. x Bev.) x 5" Long		11.90	15	W01052160706000	8	Flatwasher 3/8, Nom.	0.15
7	68034-M	1	Cap, 8" Std. (Sp. Grv.)		12.00	16	L03052000006000	4	Lockwasher Std. Spiral 3/8	0.12
8*	F245	1	Underflow Pan	101.10		17	N19052061600000	4	Hex Nut 3/8-16	0.10
9	DBLFG100	1	Pressure Gauge, 0-60		0.50	18	68031	1	Plug	0.25
									TOTAL WEIGHT (Lbs.):	1219.92

\* Part of Item 1. Shown as Replacement Item.

CAPACITY: 1,050 gpm @ 70 Feet of Head  
3,974 lpm @ 21.34 Meters of Head

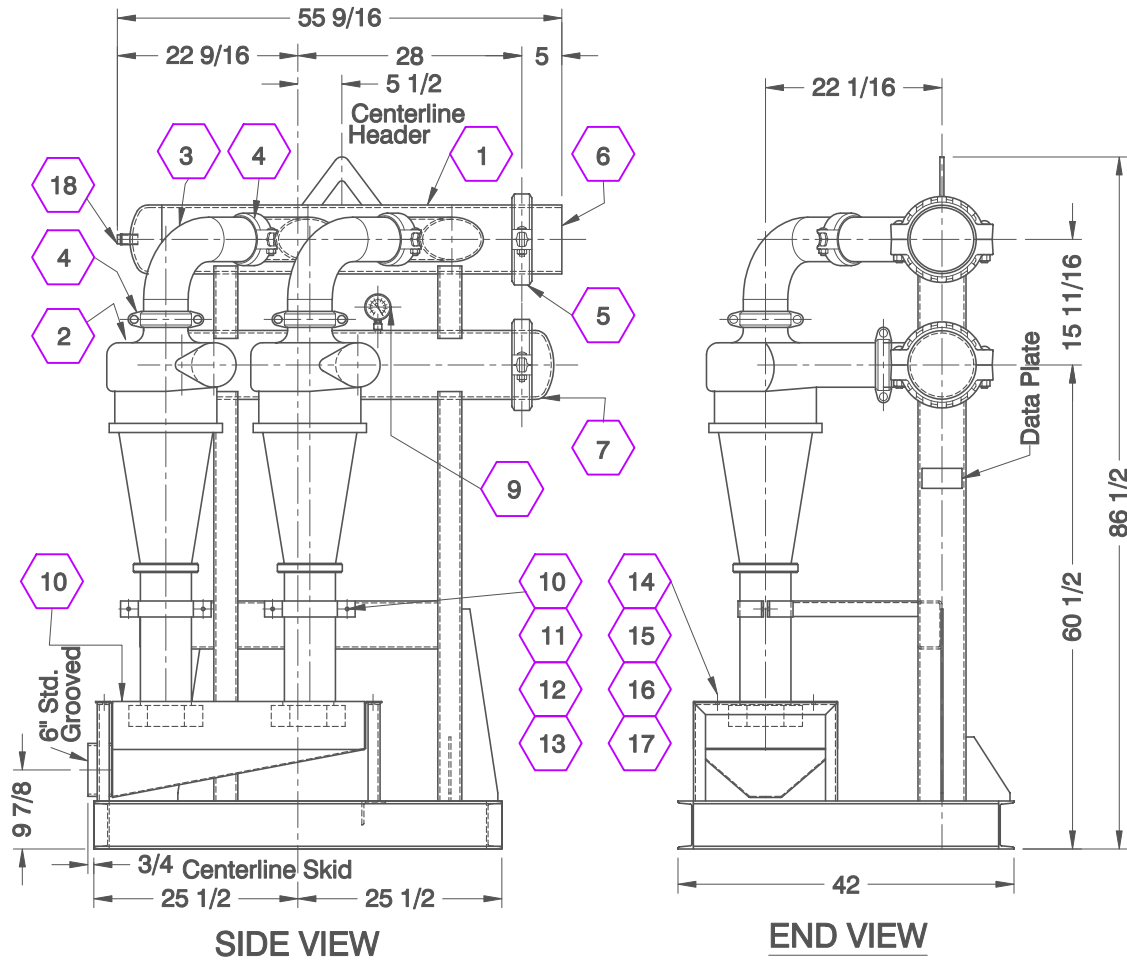

REVISIONS		DATE
BY	DH	01/21/99
	DH	5/18/99

NO.	ZONE	DESCRIPTION
1	All	General Revision
2		+ Dim. @ End View

NOTES	
1.	All dimensions are in inches unless otherwise noted.
2.	Ref. Dwg. No. 27-00235 for Assembly.

**NOTICE**  
The information contained herein is proprietary and may not be copied or transmitted to another party without the written consent of the owner, THE DOUBLE LIFE CORP., INC.

**DL** the double life corp., inc.

TITLE  
**CUSTOMER DRAWING  
INSTALLATION DRAWING & PARTS LISTING  
MODEL NO. V-210 DESANDER**

PART NO.	69030	DRAWN BY	JDH	DATE	1/5/99	SCALE	NTS
SHEET NO.	1/1	DRAWING NO.	99-00246	REV. NO.	2	SIZE	A
						REV. BY	SB
						SEC.	1